

# CKASE

## BORA cooktop extractor system

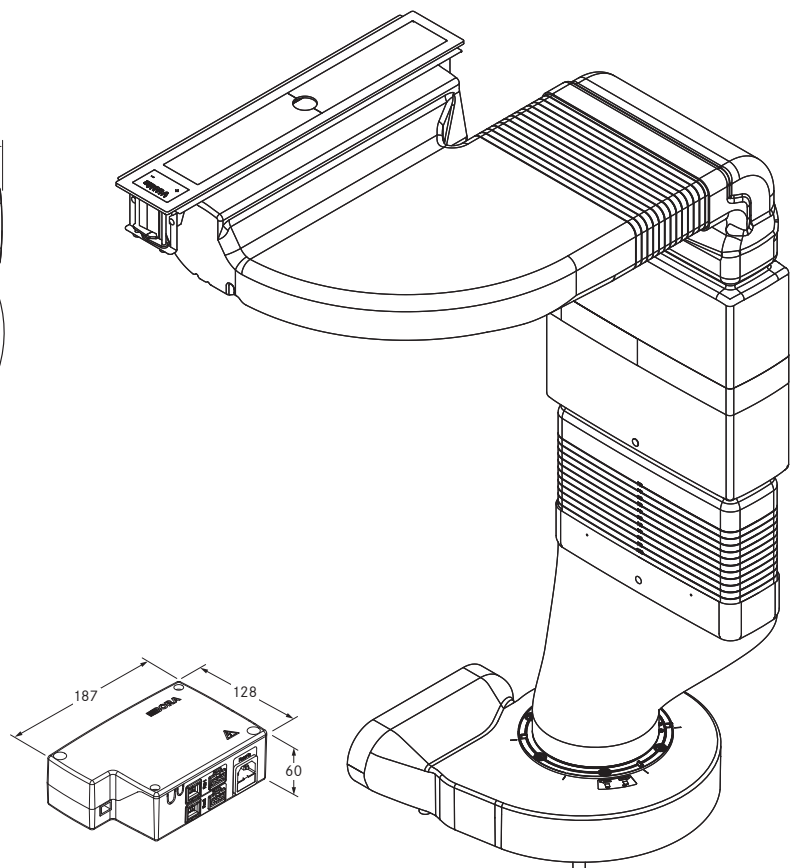
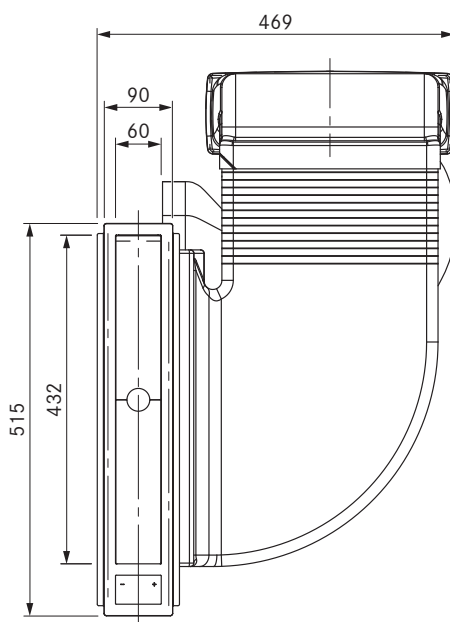
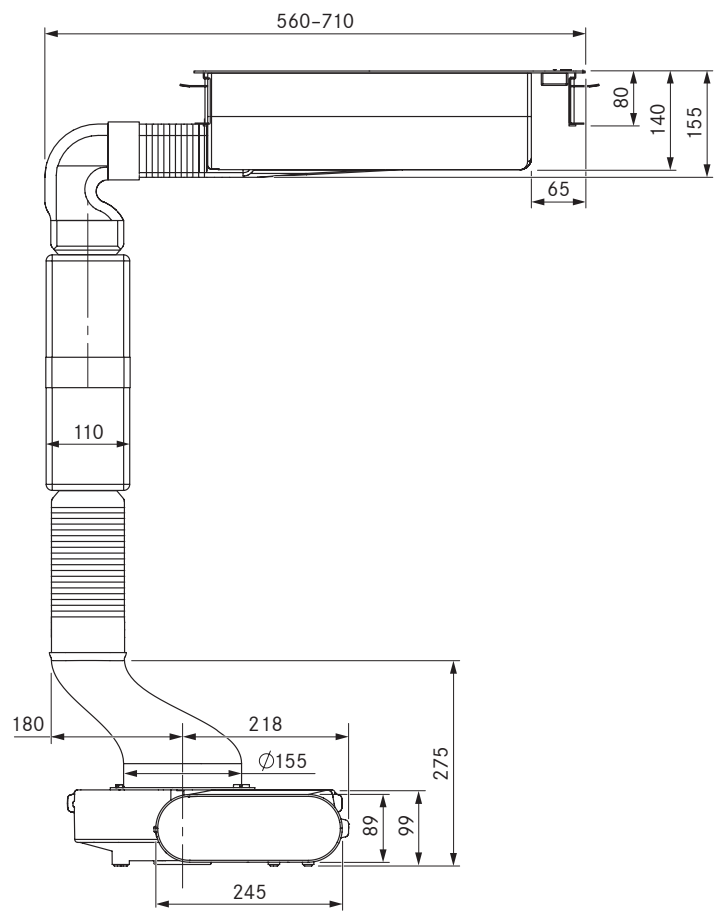
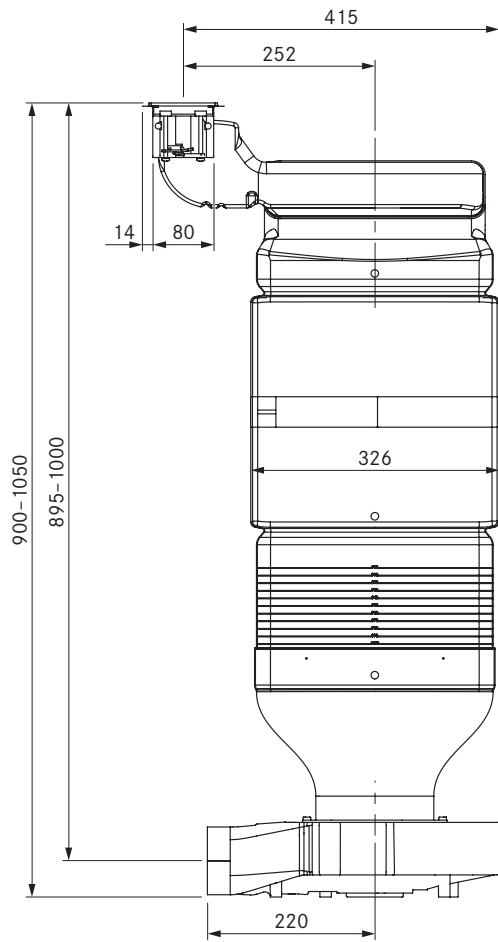

## BORA cooktop extractor system

### Technical data

Supply voltage	220 – 240 V
Frequency	50/60 Hz
Maximum power consumption	170 W
Fuse protection (internal)	3.15 A
Power supply cable	1 m
Dimensions (WxDxH)	90 x 515 x 140 mm
Weight (incl. accessories/packaging)	11.0 kg
Surface material	Brushed stainless steel
Power levels	1 – 5
Connection on the exhaust side	BORA Ecotube

### Product description

- 5 power levels
- Power levels controlled using intelligent touch operation
- Smallest installation dimensions – depth of 600 mm from the front edge
- Stainless steel grease filter
- 20-minute automatic after-run
- Filter service display
- Safety shut-down
- Interface for external devices via Home In or Home Out
- Ability to connect a further BORA ULIE additional duct fan

### Scope of delivery

- CKASE cooktop extractor system (cooktop extractor with electronic controls, stainless steel grease filter, substructure module, protective grid, silence module, curved and straight transition pieces and 2 cover plates)
- ULS plinth fan
- CSEE Classic control unit
- CAT 5 communication cable
- Sealing tape for the cooktop extractor
- Sealing tape
- Height adjustment plate set
- Operating and installation instructions
- Power supply cable with type E + F plugs

### Planning instructions

- Can be combined with all BORA Classic cooktops
- The worktop height and depth can be flexibly adjusted
- The cooktop extractor system can be installed in a carcass depth of 600 mm
- Exhaust ducting only possible to the right
- Installation type: flush or surface-mounted
- Fan can be positioned in the plinth area as a result of the low installation height (100 mm)
- The Classic control unit can be simply and compactly positioned in the plinth area as the central connection point
- The touch control and Classic control unit are connected via a CAT 5 communication cable
- The drawers and/or shelves in the floor unit must be removable for maintenance and cleaning purposes
- In case of an exhaust channel of more than 6 m in length or significant pressure losses, the plinth fan must be supplemented with a BORA ULIE additional duct fan
- The BORA Ecotube duct system is optimally tailored to the BORA cooktop extractors and guarantees 100% functionality and optimum performance
- The Classic cooktop extractor system can be combined with USTF, USTE, USTJ, USTG and USTL sockets

### Accessories

- CKAAB0 cover plate (x 1)
- CKAEG air inlet grille
- UEF stainless steel grease filter
- UFH ferrite sleeve set
- UNLI type I power supply cable (AUS)
- UNLJ type J power supply cable (CH)
- UNLG type G power supply cable (GB-IE)